



Network Testing and Emulation Solutions

<http://www.candelatech.com>
sales@candelatech.com
+1 360 380 1618 [PST, GMT -8]

CT503 High-Speed LANforge-FIRE Traffic Generator

The CT503 is an excellent choice for testing high-performance networks and network components. The CT503 consists of a single 1U multi-core system with 8 10/100/1000 Ethernet interfaces. The system can generate and receive close to line speed on each port when using Armageddon and larger packet sizes. Other quantities of ports are available, and additional systems can be clustered for increased traffic generation capacity.

The CT503 1U rackmount chassis fits into a standard rack and is about 14 inches deep. It supports standard VGA, Keyboard, and Mouse interfaces for easy console/desktop access to the system. The rackmount chassis is relatively noisy, so it is better for a data center deployment than a desktop environment. Other form factors better suited for traveling or desktop use are also available at similar prices and performance. **This system includes the Armageddon feature at no additional charge.** VoIP and virtual interface support is priced separately. Please communicate your preferences to your sales representative. No additional hardware or software is required, but you may wish to manage the system using the LANforge-GUI on a separate machine.



NOTE: This product may have a different hardware configuration than the system pictured above.
Refer to your official quote for details.

Candela Technologies Inc., 2026 Main Street, Suite A, P.O. Box 3285, Ferndale, WA 98248, USA
www.candelatech.com | sales@candelatech.com | +1 360 380 1618

Example Network Diagram



LANforge FIRE Traffic Generator.

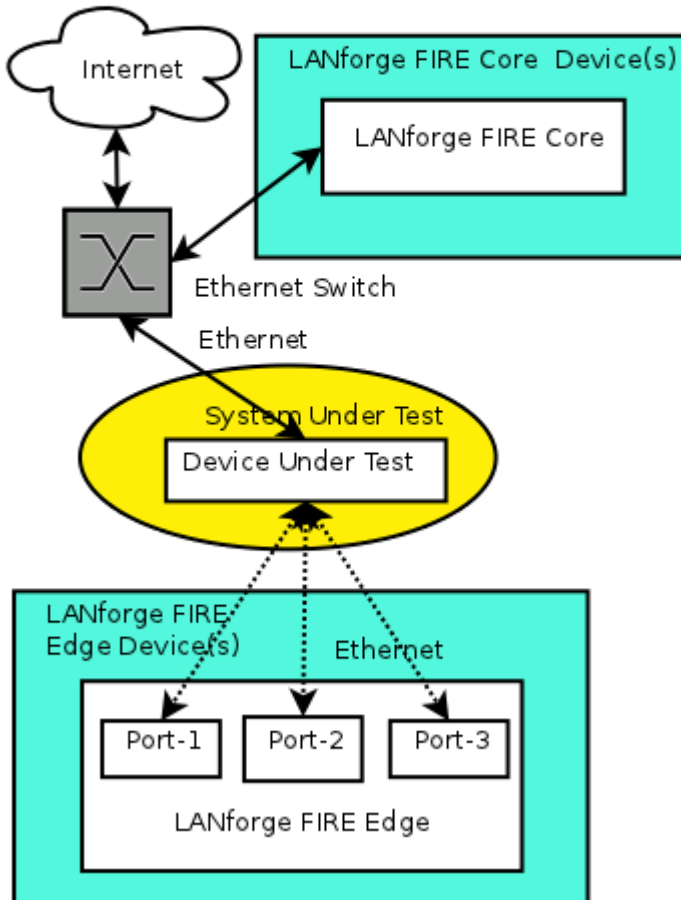

LANforge FIRE supports multiple Ethernet interfaces. To the System Under Test, it appears as if each interface is a separate PC or network appliance generating independent stateful traffic streams.

Thousands of 802.1Q and MAC-VLAN virtual interfaces are also supported. LANforge can send traffic between any two interfaces, including two interfaces on the same machine. Each physical and virtual interface can be configured on the same, or on different IP subnets.

In the configuration on the left, the LANforge FIRE Core can be one interface and act as the server. The LANforge FIRE Edge can be other interfaces on the same system. It is also valid to use multiple LANforge systems configured to act as a single realm. Using multiple systems can increase total throughput and is necessary when endpoints are physically far apart.

Quick Start Guide

1. Connect Management ethernet port to Management network or management PC. If connecting directly to a PC, an ethernet cross-over cable should be used. Or, connect VGA, Keyboard, and Mouse to the chassis and manage it locally.
2. Connect one or more traffic generating ports to the downstream side of the device under test. This usually is considered the 'client' side of the network.
3. Connect one or more traffic generating ports to the upstream side of the device under test.
4. Connect power plug to a standard US or European AC power source.
5. If managing remotely, install the LANforge-GUI on a separate management PC or Laptop. Windows and Linux GUIs are supported: Select the correct one from the CDROM or Candela Technologies Download page and install it.
6. The CT503 should now boot. If DHCP is enabled on the Management network, the CT503 will automatically acquire an IP address. If DHCP is not available, the IP address will be set to 192.168.1.101 by the LANforge scripts.
7. Start the LANforge-GUI on the management PC, or the CT503 server if managing locally, and click the 'Discover' button. It should find the CT503 appliance and add the IP address to the drop-down box in the Connect widget. Press 'Connect' and you will be connected to the CT503.
8. Select the Layer 3, Armageddon, Layer 4 and other LANforge-FIRE related tabs in the GUI to see existing traffic connections and to modify them or add new ones. You can also view a real-time report of the test with the 'Display' button for some traffic types.
9. LANforge can send Layer 3, Armageddon and most other traffic types between any two physical ports, so one can send traffic between port eth0 and eth1, eth0 and eth2, eth3 and eth4, etc. Use the Port Mgr tab in the GUI to configure the IP addresses for the interfaces as appropriate for your network and cabling.
10. Any modifications take place immediately after you click 'Submit'.

*Candela Technologies Inc., 2026 Main Street, Suite A, P.O. Box 3285, Ferndale, WA 98248, USA
www.candelatech.com | sales@candelatech.com | +1 360 380 1618*

LANforge-FIRE Related Screen Shots

Layer 3 (Ethernet, UDP, TCP) Connections

LANforge Manager Version(5.2.4)

Control Reporting Tear-Off Help

Rpt Timer: fast (1 s)
 Test Manager: all

View: all

Cross Connects for Selected Test Manager

Name	Type	State	Pkt Tx A->B	Pkt Tx A<-B	Rate A->B	Rate A<-B	Rx Drop ...	Rx Drop ...	Drop Pkts A	Drop Pkts B	Latency	Rpt
sta-sta-t1	LF/TCP	Stopped	0	0	0	0	0	0	0	0	0	0
sta-sta-t2	LF/TCP	Stopped	0	0	0	0	0	0	0	0	0	0
sta-sta-u1	LF/UDP	Stopped	0	0	0	0	0	0	0	0	0	0
sta-udp-s	LF/UDP	Stopped	0	0	0	0	0	0	0	0	0	0
tcp-d-001	LF/TCP	Stopped	0	0	0	0	0	0	0	0	0	0
udp-0001	LF/UDP	Run	2,244	56	383,983	9,582	0	0	0	0	3	
udp-0002	LF/UDP	Run	2,244	56	383,988	9,582	0	0.045	0	1	5	
udp-0003	LF/UDP	Run	2,244	56	383,988	9,582	0	0.045	0	1	8	
udp-0004	LF/UDP	Run	2,244	56	383,988	9,582	0	0.045	0	1	10	
udp-0005	LF/UDP	Stopped	0	0	0	0	0	0	0	0	0	0
udp-0006	LF/UDP	Stopped	0	0	0	0	0	0	0	0	0	0
udp-0007	LF/UDP	Stopped	0	0	0	0	0	0	0	0	0	0
udp-0008	LF/UDP	Stopped	0	0	0	0	0	0	0	0	0	0

Logged in to: 192.168.100.195:4002 as: Admin

Layer 3 Create/Modify Screen

Create/Modify Cross Connect

Cross Connect Information

CX Name: tcp6-nrml
 CX Type: LANforge / TCP6
 Report Timer: fast (1 s)
 Quiesce: 3
 Test Manager: default_tm

TX Endpoint (endpoint A)

Endp Name: tcp6-nrml-A Shelf: 1 Resource: 1 (dec2010-ath9k-1) Port: 10 (rddVR0)

Pld Pattern: Increasing IP Addr: AUTO Min IP Port: AUTO Max IP Port: Same

Min Tx Rate: 10M (10 Mbps) Max Tx Rate: Same Min Pkt Size: TCP P1d (1,460 B) Max Pkt Size: Same

IP ToS: Best Effort (0) Pkts To Send: Infinite TTL: 32

Min Duration: Forever Max Duration: Same Min Recon: 0 (0 ms) Max Recon: Same

Multi-Conn: Normal (0) Filename: Dest MAC: b2 e3 d9 eb 14 f4

Checksum
 UnManaged
 Rcv Mcast
 Replay File
 Loop
 Dest Mac

RX Endpoint (endpoint B)

Endp Name: tcp6-nrml-B Shelf: 1 Resource: 1 (dec2010-ath9k-1) Port: 15 (rddVR5)

Pld Pattern: Increasing IP Addr: AUTO Min IP Port: AUTO Max IP Port: Same

Min Tx Rate: 10M (10 Mbps) Max Tx Rate: Same Min Pkt Size: TCP P1d (1,460 B) Max Pkt Size: Same

IP ToS: Best Effort (0) Pkts To Send: Infinite TTL: 32

Min Duration: Forever Max Duration: Same Min Recon: 0 (0 ms) Max Recon: Same

Multi-Conn: Normal (0) Filename: Dest MAC: 4e aa 68 16 1c 9d

Checksum
 UnManaged
 Rcv Mcast
 Replay File
 Loop
 Dest Mac

Software Features

- Supports real-world protocols:
 - Layer 2: Raw-Ethernet.
 - 802.1Q VLANs.
 - PPPoE: Integrated PPPoE support.
 - Layer 3: IPv4, IPv6, UDP/IP, IGMP Multicast UDP, TCP/IP.
 - Layer 4: FTP, HTTP, HTTPS, TFTP, SFTP, SCP
 - Layer 3: Armageddon accelerated UDP/IP (line speed on appropriate hardware).
 - Layer 4: TELNET, PING, DNS, SMTP, NMAP (via add-on script).
 - File-IO: NFSv3, NFSv4, CIFS, iSCSI.
- Supports up to 1000 concurrent TCP connections with base license package.
- The CT503 is able to generate around 8Gbps, depending on protocol mix and speed of the network under test. Supports at least 500 VoIP (SIP, RTP) calls if appropriate licenses are purchased. The portable chassis configurations may run at different speeds than the 1U or 2U rackmount systems.
- Hardware supports over 30,000 TCP connections on a single machine, but base license package includes 1000 licenses. Contact sales for additional licenses.
- Supports real-world compliance with ARP protocol.
- Supports ToS (QoS) settings for TCP/IP and UDP/IP connections.
- Uses publicly available Linux, Windows and Solaris networking stack for increased standards compliance.
- Utilizes [libcurl](#) for FTP, HTTP and HTTPS (SSL), TFTP and SCP protocols.
- Supports file system test endpoints (NFS, CIFS, and iSCSI file systems, too!). File system mounts can use the virtual interface feature for advanced testing of file server applications.
- Supports custom command-line programs, such as telnet, SMTP, and ping.
- Comprehensive traffic reports include: Packet Transmit Rate, Packet Receive Rate, Packet Drop %, Transmit Bytes, Receive Bytes, Latency, Jitter, various Ethernet driver level counters, and much more.
- Supports generation of reports that are ready to be imported into your favorite spread-sheet.
- Allows packet sniffing and network protocol decoding with the integrated [Wireshark](#) protocol sniffer.
- GUI runs as Java application on Linux, Solaris and Microsoft Operating Systems (among others).
- GUI can run remotely, even over low-bandwidth links to accommodate the needs of the users.
- Central management application can manage multiple units, tests, and testers simultaneously.
- Includes easy built-in scripting for iterating through rates and packet sizes, with automated reporting. Also supports scriptable command line interface (telnet) which can be used to automate test scenarios. Perl libraries and example scripts are provided!
- Automatic discovery of LANforge data generators simplifies configuration of LANforge test equipment.
- LANforge traffic generation/management software is supported on Linux, Solaris and MS Windows.

*Candela Technologies Inc., 2026 Main Street, Suite A, P.O. Box 3285, Ferndale, WA 98248, USA
www.candelatech.com | sales@candelatech.com | +1 360 380 1618*

Hardware Specification

- High-End Intel Multi-Core 1U rackmount server.
- Operating System: Fedora 64-bit Linux with customized Linux kernel.
- 4 built-in 10/100/1000 Ethernet interfaces, one of which should be used for management.
- High-availability Ethernet hardware bypass option available.
- One Quad-Core Intel E3 processor, 3+Ghz
- 1 PCIe x16 slot (2-6 port 10/100/1000, 1-2 port 10G fibre, etc)
- 8 GB or more RAM.
- 40 GB or larger Hard Drive.
- Solid State Drive option available.
- Slim CDROM drive.
- Standard US or European power supply (automatically detects EU v/s US power).
- Weight: 18 lbs or 8.2 kg.
- Dimensions: 17 x 14 x 1.75 inches (14-inch deep 1U rackmount server) Metric: 432 x 356 x 44 mm.
- Power Supply: Fixed 350W AC
- Estimated Power Usage: 1.4 Amps @ 120VAC under load, 0.7 Amps idle.
- ROHS compliant.

List Price: \$16,295 List Price with 1 Year support: \$19,065

Feature Upgrades

Unless otherwise noted, these features usually cost extra:

- WanPaths (LANforge-ICE feature set)
- Virtual Interfaces: MAC-VLANs, 802.1Q VLANs, WiFi stations, etc
- FIRE Connections: Base FIRE license includes 1000 active connections.
- LANforge-ICE Network Emulation.
- VOIP: Each concurrent call requires a license.
- Armageddon: Each pair of ports requires a license.

*Candela Technologies Inc., 2026 Main Street, Suite A, P.O. Box 3285, Ferndale, WA 98248, USA
www.candelatech.com | sales@candelatech.com | +1 360 380 1618*

Last modified: Mon May 14 11:36:37 PDT 2012